

## SUBMITTAL DATA commercial fin tube radiation

### Model SF Slope Top, Floor Mounted

Job name & location \_\_\_\_\_ Date \_\_\_\_\_  
 Architect \_\_\_\_\_ Engineer \_\_\_\_\_ Sheet \_\_\_\_\_ of \_\_\_\_\_  
 Contractor \_\_\_\_\_ Order No. \_\_\_\_\_  
 Submitted by \_\_\_\_\_

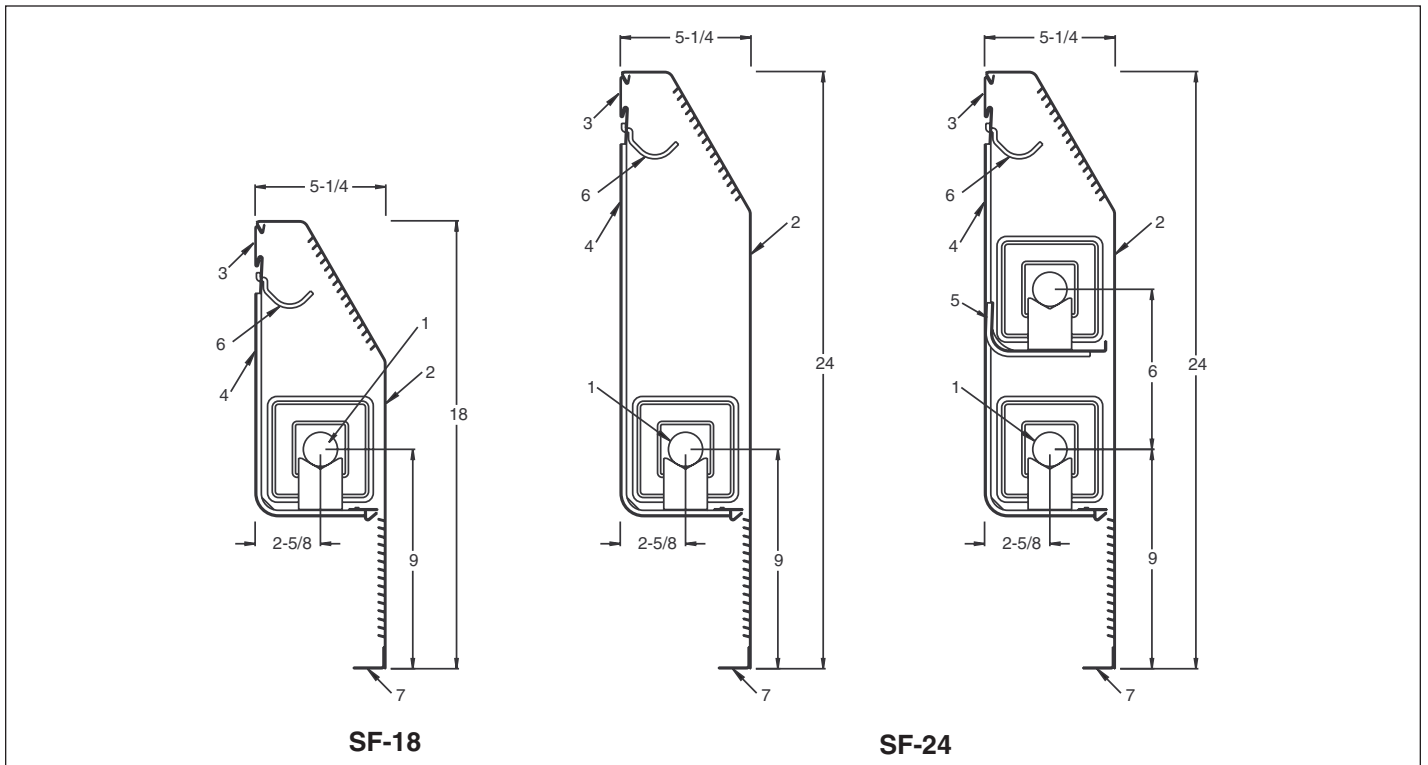

- 1 - Heating Element
- 2 - Enclosure
- 3 - Hanger Strip

- 4 - Enclosure Wall Support (EWS)
- 5 - Element Support Assembly (ESA)
- 6 - Return Pipe Hanger
- 7 - Floor Angle

### Enclosure Specifications

Lengths: 2' to 8' in 6" increments  
 Model:  SF-18  SF-24  
 Gauge:  18 ga.  16 ga.  14 ga.  
 Standard Baked Enamel Finish:  TR-13 Tan  
 Optional Baked Enamel Finish:  
 Per AIR75-402 \_\_\_\_\_  
 Per AIR75-400 \_\_\_\_\_  
 Dampers:  Knob Operated  Tamper Proof

### Heating Element Specifications

Seamless copper tube diameter:  
 3/4"  1"  1-1/4"  
 Aluminum fin size:  
 4-1/4" x 4-1/4"  2-3/4" x 4-1/4"  
 Aluminum fins/ft:  
 34  42  50  
 Rows of Elements:  
 1  
 2 @ 6"

### Performance

Average water temperature \_\_\_\_\_ °F  
 Water flow rate: \_\_\_\_\_ GPM, \_\_\_\_\_ Ft/sec.  
 Steam Pressure: \_\_\_\_\_ psi  
 Entering Air Temperature: \_\_\_\_\_ °F  
 Rating: \_\_\_\_\_ Btu/hr/ft

# AIR12-425.1

## Model SF Slope Top, Floor Mounted

Floor Angle  Single Floor Angle  Double Floor Angle

Available in lengths of 2' to 8' in 6" increments

### Enclosure Supports

Enclosure wall supports (EWS):

- 18" enclosure  EWS-18  
 24" enclosure  EWS-24

Enclosure wall support (EWS) with one element cradle attached:

- 3/4" & 1" tube 1-1/4" tube  
 18" enclosure  EWS-1275  EWS-1212  
 24" enclosure  EWS-1875  EWS-1812

Element support assembly (ESA):

- 3/4" & 1" tube  ESA-75  
 1-1/4" tube  ESA-12

**NOTE:** For models SF and RF, use one smaller mounting support bracket. Ex: for 24" enclosure, use 18" support bracket.

### Accessories - 20 gauge

- 18" enclosure  24" enclosure

- Wall support - left  
 Wall support - right  
 5" Wide enclosure extension (O)  
 12" Wide enclosure extension (O)  
 12" Wide enclosure extension w/access door (O)  
 90° Inside corner (O)  
 90° Outside corner (O)  
 12" Wide valve compartment (S)

- 18" Wide valve compartment (S)  
 12" Wide end enclosure - left (S)  
 12" Wide end enclosure - right (S)  
 12" Wide end enclosure w/access door - left (S)  
 12" Wide end enclosure w/access door - right (S)  
 End cap - left (S)  
 End cap - right (S)

(O) overlapping fit (S) slip joint fit to enclosure

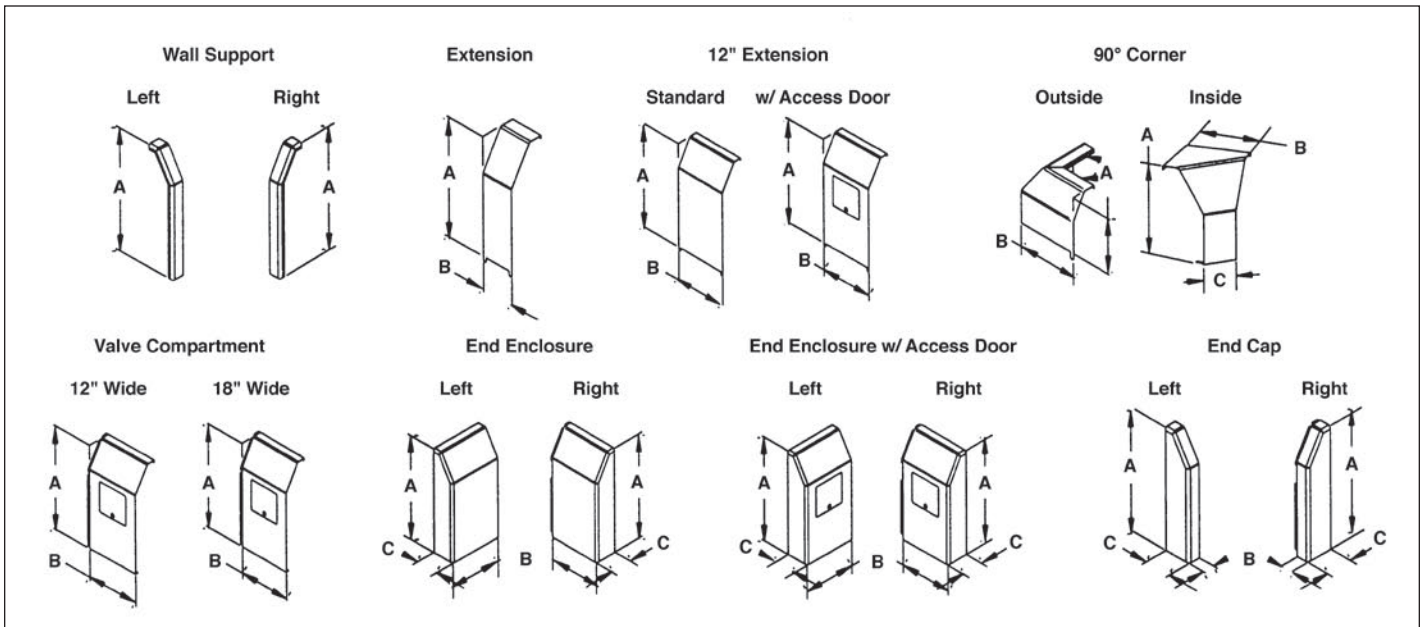

### Accessory Dimensions

Enclosure	Dim	12" Extension		90° Corner		Valve Compartment		End Enclosure		End Cap		
		Wall Support	Extension	Standard	w/Access Door	Inside	outside	12" Wide	18" Wide		Standard	w/Access Door
SF-18/24	A	18/24	18/24	18/24	18/24	18/24	18/24	18/24	18/24	18/24	18/24	18/24
	B		5	12	12	8.25	9	12	18	12	12	2.25
	C					4.25				5.25	5.25	5.25